

Crazy Iron



YAMAHA MT-07 2014-2023
ID: 3400217/3400117

Installing:

Left side:

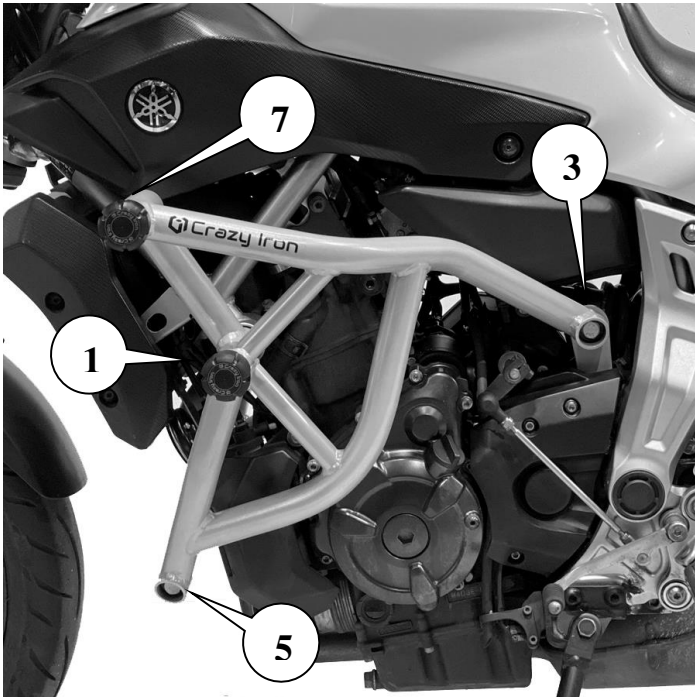

Right side:

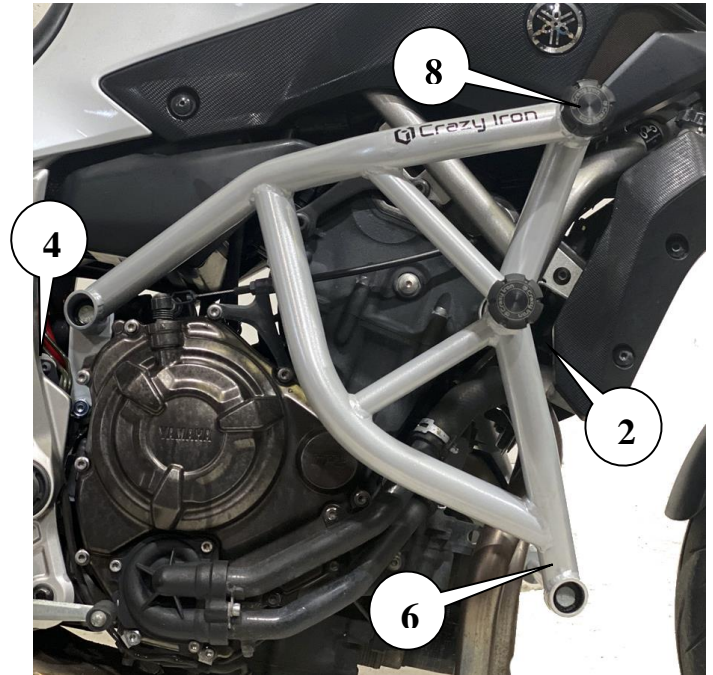

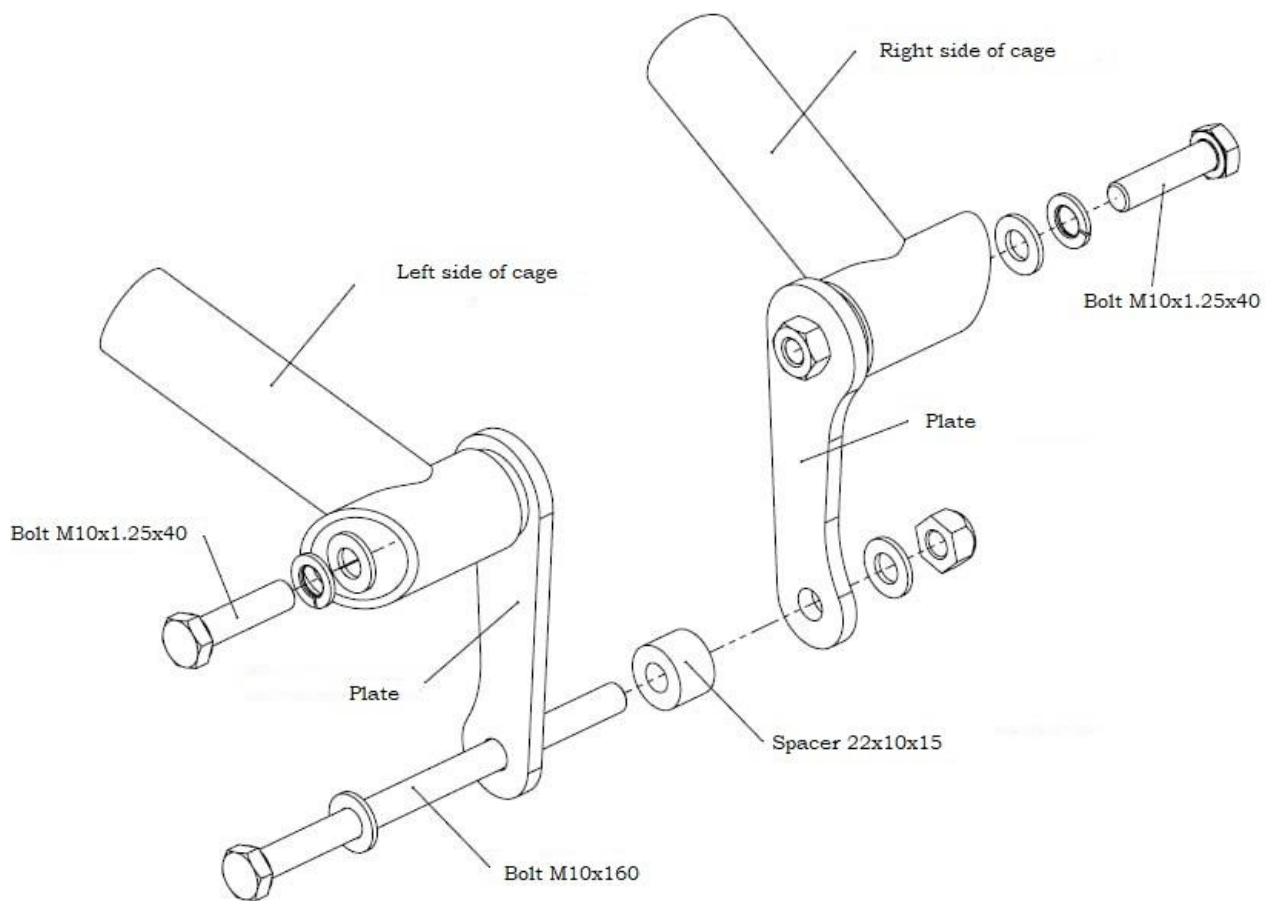





















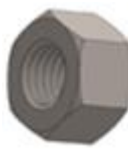

Comments:

1. Contact a specialized service, do not install the cage yourself!
2. Remove front sprocket cover.
3. Attach Plate with Bolt lightly M10x160 through the spacer 22x10x15 in point №3 Plate in point №4.
4. Tight lightly the nut at point № 4 to keep the mounting ears movable.
5. Remove original bolt in point №1.
6. Attach left side of cage at points №1 and №3.
7. Screw lightly Bolt M12x1,25x100 in point №1 and screw lightly Bolt M10x1,25x40 in point №3. Correct the position of the Plate.
8. Remove original bolt in point №2
9. Attach right side of cage at points №2 и №4.
10. Attach right side of cage at points №2 with Bolt M12x1,25x100 lightly and in point 4 with Bolt M10x1,25x40 lightly. Correct the position of the Plate 053.
11. Install between points №5 and №6 the brace (L= 265 mm) and fix it with Bolts M10x1,25x30.
12. Tighten the fasteners according to the table.
13. Install Damper sliders in points №№1,2,7,8.
14. Put front sprocket cover back.

Tightening torques Nm		
Thread	Connection type	
	Steel	Aluminum
M6	10	6
M8	24	20
M10	48	35
M12	56	45

NEVER LOOSEN ENGINE BOLTS FROM THE LEFT AND RIGHT SIDES AT THE SAME TIME!!!

Component table with according numbers in the photo:

№	Items			
1	Bolt M12x1.25x100	Spring washer	Washer	Damper slider
				
2	Bolt M12x1.25x100	Spring washer	Washer	Damper slider
				
3	Bolt M10x160	Washer	Plate	Spacer 22x10x15
				
4		Plate	Washer	Nut
				
5	Bolt M10x1,25x30	Spring washer	Washer	Brace L=265
				
6		Bolt M10x1,25x30	Spring washer	Washer
				
7		Damper slider		
				
8	Damper slider			