

Crazy Iron

KTM 390 ADVENTURE
ID 9007112/9007117



Complete set and assembly scheme:

Left side:

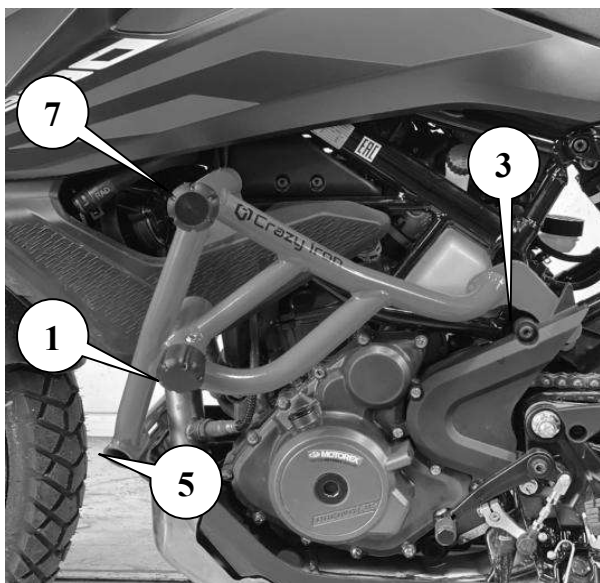

Place for mounting of plate:

Right side:

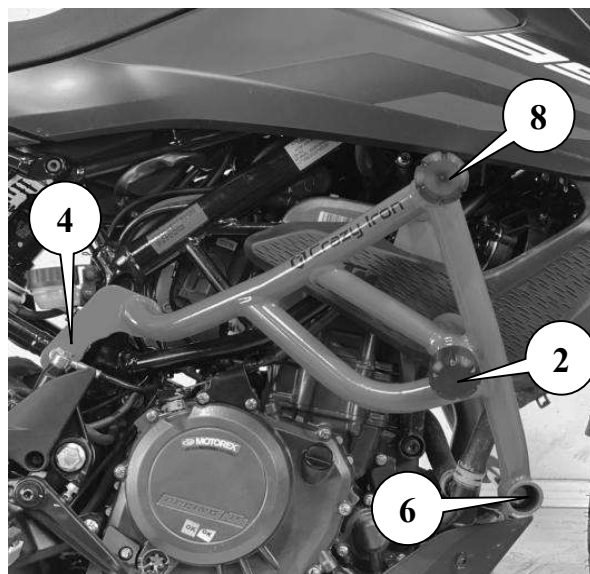

Fitting of plate

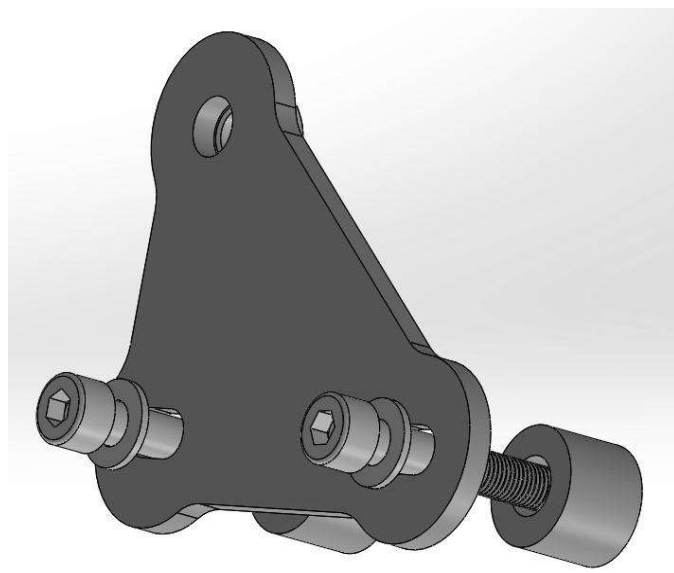
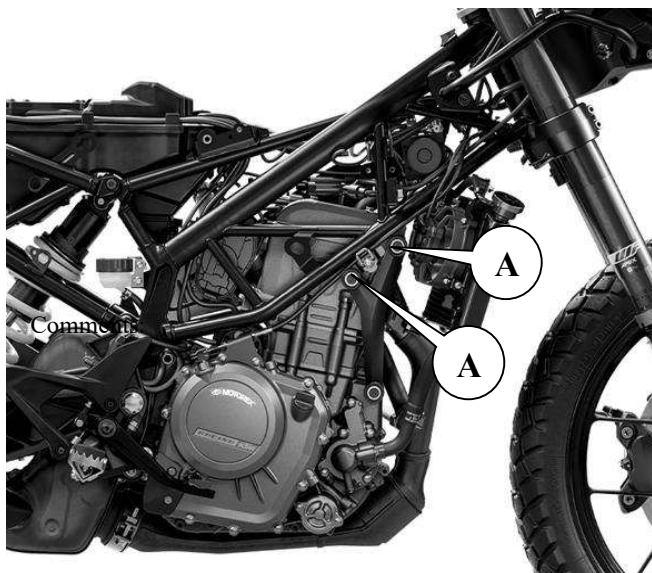

Comments:

NEVER LOOSEN ENGINE BOLTS FROM THE LEFT AND RIGHT SIDES AT THE SAME TIME!!!

1. Contact a specialized service, do not install the cage yourself!
2. Remove fairing elements if they can interfere the installation of Plate
3. Remove original bolt from points A on the right side and attach Plate to points A with bolts and spacers and fix.
4. Remove original bolt from points A on the left side and attach Plate to points A with bolts and spacers and fix.
5. Install fairing back.
6. Remove original bolts from point 4 on the right side of motorcycle.
7. Attach right side of cage to points 4 and 8 and fix with bolt M8x50 through spacer 16x10x20 in point 4 and with bolt M10x40 in point 8
8. Remove original bolts from point 3 on the right side of motorcycle.
9. Attach right side of cage to points 3 and 7 and fix with bolt M8x50 through spacer 16x10x20 in point 3 and with bolt M10x40 in point 7
10. Install between points No5 and No6 the brace (L= 245 mm) and fix it with Bolts M10x1,25x30
11. Tighten the fasteners according to the table.
12. Install sliders in points NoNo1,2,7,8 and fix them with screws, in case Damper cage use Damper sliders.

Tightening torques Nm		
Thread	Connection type	
	Steel	Aluminum
M6	10	6
M8	24	20
M10	48	35
M12	56	45

Component table with according numbers in the photo:

№	Items							
1	Slider	Screw						
								
2	Slider	Screw						
								
3	Bolt M8x50	Spacer 16x10x20	Spring washer	Washer				
								
4	Bolt M8x50	Spacer 16x10x20	Spring washer	Washer				
								
5	Bolt M10x1,25x30	Spring washer	Washer	Brace L=245				
								
6	Bolt M10x1,25x30	Spring washer	Washer					
								
7	Plate	Bolt M8x50	Spring washer	Spacer 20x10x17	Slider	Screw		
								
								
		Bolt M10x40						
								
8	Plate	Bolt M8x60	Spring washer	Spacer 20x10x32	Slider	Screw		
								
								
		Bolt M10x40						
								